

MILLIVOLT GAS FRYERS

SG18-3/FD



For high production gas economy frying, specify Pitco Solstice gas tube fryers with the patented Solstice Burner Technology. These dependable millivolt fryers feature a blower-free atmospheric heating system that provides fast recovery to cook a variety of food products. The Solstice gas fryer comes standard with a millivolt thermostat with a thermo-safety pilot and high temperature safety limit switch. The unique Solstice burner and baffle design increases cooking production, lowers flue temperature, and improves the working environment compared to previous models.

STANDARD FRYER FEATURES & ACCESSORIES

- Tank - stainless steel construction
- Cabinet - stainless front, door and sides
- Solstice Burner Technology, No blower or ceramics
- Millivolt thermostat (T-Stat) 190°C-93°C CE
- Thermo-Safety pilot with built in regulator
- High temperature safety limit switch
- Heavy duty 3/16" bottom door hinge
- 1 ¼" (32 mm) Full port drain valve for fast draining
- Separate manual gas shutoffs, for front servicing
- Integrated flue deflector
- 9" (229 mm) adjustable legs, easier access to clean
- Tube rack, allows crumbs & debris into cool zone
- Removable basket hanger, requires no tools
- Washdown/discharge hose
- Drain line clean out rod, lids and brush
- Drain extension
- Fryer cleaner sample packet
- 3 Baskets per tank

THREE FRYER FILTER SYSTEM

- Simple two-step filtration
- Fast filtering with a 30L per minute pump for quick oil refills
- Easy, hassle-free hookup with a self-aligning filter connection
- Rear oil return helps clean the fryer bottom
- Durable stainless steel filter pan with rear wheels for easy movement
- Convenient self-storing lid stays out of the way



Millivolt Thermostat



Please note, due to ongoing product development and improvement, we reserve the right to change product design and specification at any time without notice.

 **MIDDLEBY**
AUSTRALIA

**HEAD OFFICE
AND MANUFACTURING PLANT**
211-217 Woodpark Road
Smithfield NSW 2164

VIC - TAS
47 Stubbs Street,
Kensington
VIC 3031

QLD
U12, 210 Queensport
Rd Nth, Murarrie
QLD 4172

WA
U2, 9 Meares Way,
Canning Vale WA
6155

1800 013 123
+61 2 9604 7333
sales@middleby.com.au
middleby.com.au

MILLIVOLT GAS FRYERS

SG18-3/FD



SPECIFICATIONS

Dimensions (W x D x H)	1194 x 875 x 1172mm
Cooking Area (W x D) per tank	457 x 457mm
Oil Capacity per tank	38 Litres
Rating	444 MJ
Weight	319 Kg

GAS SYSTEM REQUIREMENTS

	NG	LPG
Store Supply Pressure*	17.4 mbars/ 1.7 kPa	27.4 mbars/ 2.7 kPa
Burner Manifold Pressure	10 mbars / 1 kPa	25mbars/ 2.4 kPa

INSTALLATION CLEARANCES

Front min.	762mm
Floor min.	153mm
Combustible material - Sides min.	152mm
Combustible material - Rear min.	152mm
Non-Combustible material - Sides min.	0
Non-Combustible material - Rear min.	0
Fryer Flue Area	Do not block / restrict flue gases from flowing into hood or install vent hood drains over the flue.

FILTER SPECIFICATIONS

Voltage/Frequency/Amps	240/50/3.5
Filter pump rated flow	30LPM

Minimum 10amp 240V supply, plugs required (not included).

* Check plumbing / gas codes for proper gas supply line sizing to sustain burner pressure when all gas appliances are full on.

A Electrical Connection

B 3/4" BSP Gas Connection

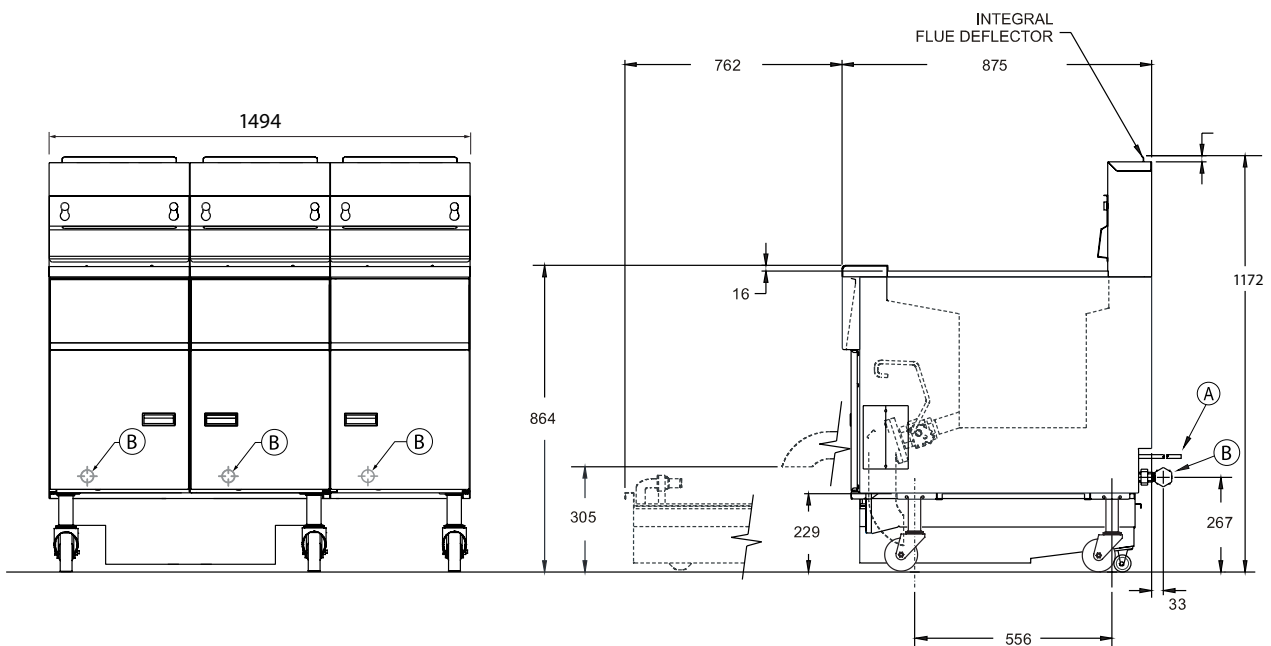
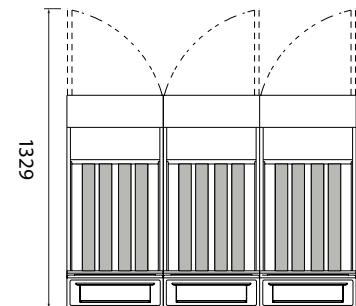

Please note, due to ongoing product development and improvement, we reserve the right to change product design and specification at any time without notice.



**HEAD OFFICE
AND MANUFACTURING PLANT**
211-217 Woodpark Road
Smithfield NSW 2164

VIC - TAS
47 Stubbs Street,
Kensington
VIC 3031

QLD
U12, 210 Queensport
Rd Nth, Murarrie
QLD 4172

WA
U2, 9 Meares Way,
Canning Vale WA
6155

1800 013 123
+61 2 9604 7333
sales@middleby.com.au
middleby.com.au