

COLD ZONE ELECTRIC FRYER

EP14-FS-2/FD



Pitco's EP14 Cold Zone Electric Fryers provide the flexibility needed to support your frying needs. The large cold zone provides for crumb collection during frying, minimising the need for filtering. The 8 Button MIC003 computer control allows programming for up to 8 menu products. Large drain system, rear oil return, and simple 2-step filter operation make this fryer easy to filter. Designed for longevity, the robust pivoting element with safety shut off allows easy access to the tank bottom for cleaning. Sturdy construction and reliable control systems are designed to provide years of dependable, trouble-free operation with minimal maintenance required.

STANDARD FRYER FEATURES & ACCESSORIES

- Tank – Stainless Steel Construction
- Cabinet – Stainless Steel Front, Door and Sides
- Patented “Lift & Hold” Heating Element
- 8 Button Computer Control
- Drain Valve Interlock
- 1-1/4” (32 mm) Full Port Drain Valve
- 9” (22.9 cm) Adjustable Castors
- Element Rack
- 1x Full Tank, 1x Split Tank
- 2 Baskets per Full Tank
- 2 Baskets per Split Tank (1 per side)
- Drain Line Clean Out Rod
- Fryer Cleaning Brush

CONTROL SYSTEM

- MIC003 Computer provides high precision electronic temperature and process control for consistent cooking performance and longer oil life
- 8 Programmable Menu Keys with individual status windows for custom recipes and real time monitoring
- Flex time compensation adjusts cook times for varying load sizes, delivering consistent food products
- Instant On feature provides immediate heat response to minimize temperature drop
- Built-in Safety Features
 - High temperature lockout
 - Element lift position detection
 - Drain valve status monitoring
- Energy Saving Mode for reduced idle power consumption

STANDARD FILTER SYSTEM FEATURES

- Easy two-step filtering
- Extra large 3” (76 mm) Drain Manifold resists clogging
- 4 GPM (15 LPM) Filter Pump
- Self-aligning filter connection for effortless hookup
- Rear oil return for cleaning tank bottom
- Filter Pan is stainless steel with rear wheels for easy handling
- Filter Paper Starter Pack



Please note, due to ongoing product development and improvement, we reserve the right to change product design and specification at any time without notice.



**HEAD OFFICE
AND MANUFACTURING PLANT**
211-217 Woodpark Road
Smithfield NSW 2164

VIC – TAS
47 Stubbs Street,
Kensington
VIC 3031

QLD
U12, 210 Queensport
Rd Nth, Murarrie
QLD 4172

WA
U2, 9 Meares Way,
Canning Vale WA
6155

**1800 013 123
+61 2 9604 7333
sales@middleby.com.au
middleby.com.au**

COLD ZONE ELECTRIC FRYER

EP14-FS-2/FD



SPECIFICATIONS

Dimensions (W x D x H)	790 x 824 x 1135mm
Cooking area per full tank	356 x 356 x 103mm
Cooking area split tank per side	172 x 356 x 103mm
Oil capacity full tank	25 Litres
Oil capacity split tank per side	2x 12.5 Litres
Rating	34kW
Weight	216Kg

INSTALLATION CLEARANCES

Front min.	762mm
Floor min.	152mm
Combustible material - Sides min.	152mm
Combustible material - Rear min.	152mm
Non-Combustible material - Sides min.	0
Non-Combustible material - Rear min.	0

Power lead and plug required (not included).

ELECTRICAL REQUIREMENTS

415/240 Volts, 24 amp per line, 50/60 Hz, 3 ph

FILTER SPECIFICATIONS

Filter pump rated flow 15LPM

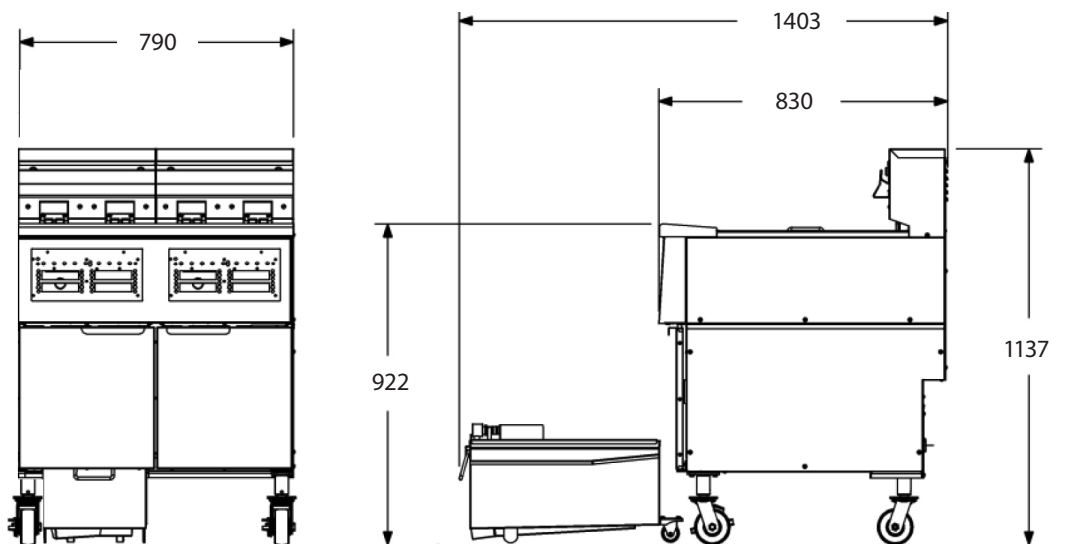
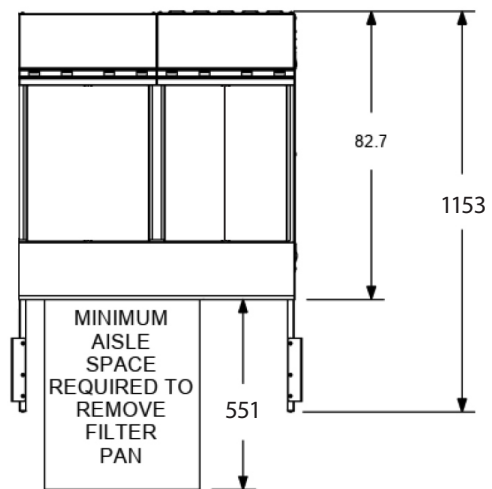

Please note, due to ongoing product development and improvement, we reserve the right to change product design and specification at any time without notice.



**HEAD OFFICE
AND MANUFACTURING PLANT**
211-217 Woodpark Road
Smithfield NSW 2164

VIC - TAS
47 Stubbs Street,
Kensington
VIC 3031

QLD
U12, 210 Queensport
Rd Nth, Murarrie
QLD 4172

WA
U2, 9 Meares Way,
Canning Vale WA
6155

1800 013 123
+61 2 9604 7333
sales@middleby.com.au
middleby.com.au