

PS3240

Electric or Gas Conveyor Oven

STANDARD FEATURES

- Impingement PLUS! low oven profile and dual air return
- 40.5" (1029 mm) long cooking chamber
- 33.5" (851 mm) wide, 76.5" (1943 mm) long conveyor belt
- Advanced technology air delivery system
- Control compartment is designed for quick and easy access
- One year parts and labor warranty
- Removable parts for easy cleaning (crumb pans, end panels, air fingers, and a folding conveyor belt assembly)
- For installation under a ventilation hood only
- "Cool skin" safety feature keeps the external surface of the oven under 120°F (49°C)

PRINCIPLE

Middleby Marshall PS Series Conveyor ovens bake both faster and at lower temperatures than other ovens. Patented vertical columns of hot air move heat aerodynamically instead of using high temperatures. The streams of hot air remove the boundary layers of cool heavy air which tend to insulate the product resulting in rapid baking without burning. All Middleby Marshall ovens are designed to cook a multitude of products.

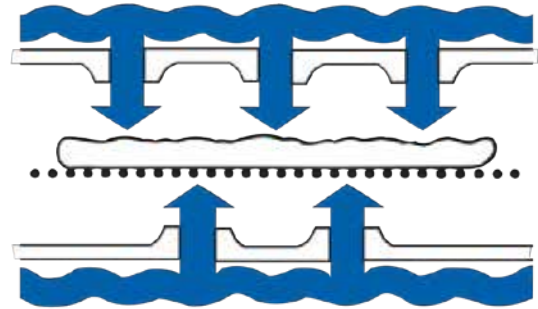

OPTIONAL FEATURES

- Split belt - two 15" (381 mm) belts with individually adjustable speed settings
- Single or split belt hearth belts

CERTIFICATIONS



Middleby Marshall reserves the right to make substitutions of components or change specifications without prior notice.

PS3240 Electric or Gas Conveyor Oven

GENERAL SPECIFICATIONS

Wall Clearance

Rear of Conveyor to Wall	0"	0 mm
Control End to Wall	0"	0 mm
Non-control End to Wall	0"	0 mm
Bake Operating Temperature	300°-600°F	149°-315°C
Time Range	1 1/4 -33 minutes	

DIMENSIONS

Single Units

Heating Zone	40.5"	1029 mm
Baking Area	9 sq ft	0.837 sq m ²
Belt Length	76.5"	1943 mm
Overall Length	76.5"	1943 mm
Height (22.13"/562 mm legs)*	47.125"	1197 mm
Depth	60"	1524 mm
Ship Weight	1100 lb.	499 kg
Ship Cube	132 ft ³	3.70 m ³

Double Stacked Units

Heating Zone	81"	2057 mm
Baking Area	18 sq ft ²	1.674 m ²
Belt Length	76.5"	1943 mm
Overall Length	76.5"	1943 mm
Height (11.25"/286 mm legs)*	61.75"	1568 mm
Depth	60"	1524 mm
Ship Weight	2200 lb.	999 kg
Ship Cube	364 ft ³	7.39 m ³

Triple Stacked Units

Heating Zone	121.5"	3086 mm
Baking Area	27 ft ²	2.511 sq m ²
Belt Length	76.5"	1943 mm
Overall Length	76.5"	1943 mm
Height (5"/127 mm legs)*	77.625"	1972 mm
Depth	60"	1524 mm
Ship Weight	3300 lb.	1498 kg
Ship Cube	396 ft ³	11.09 m ³

* Height dimensions are shown for standard leg extensions. Customer-specific leg extensions will affect these dimensions. All units are shown with casters. CE-approved ovens use 6" (152 mm) adjustable feet instead of casters.

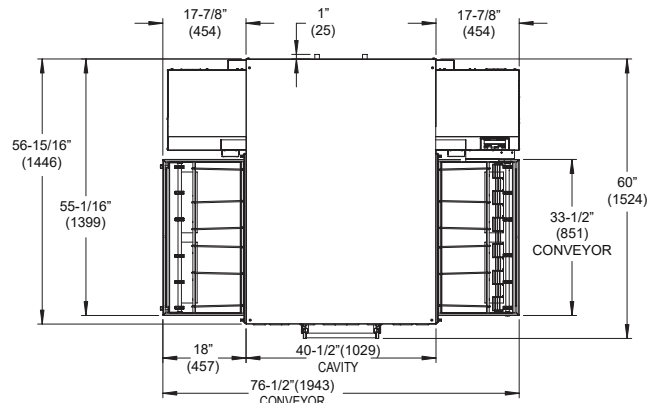

PS3240 Top View – Electric & Gas Single Unit

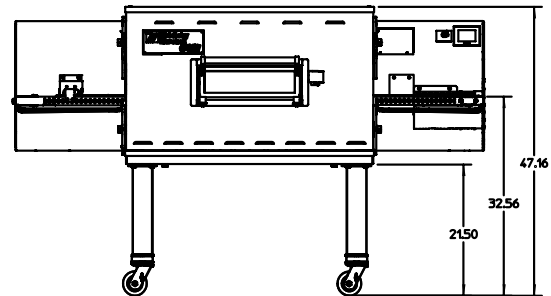

PS3240 Front View – Electric & Gas Single Unit

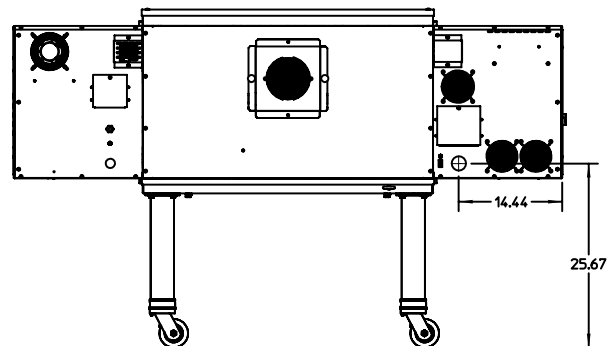

PS3240 Back View – Electric Single Unit

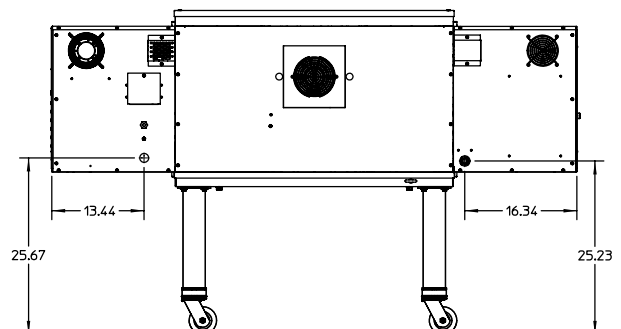

PS3240 Back View – Gas Single Unit

PS3240 Electric or Gas Conveyor Oven

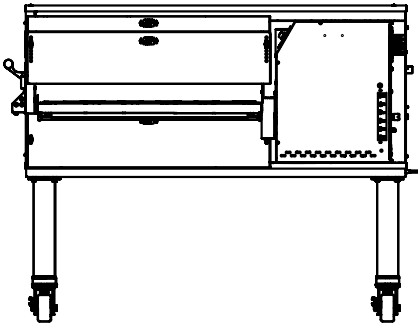

PS3240 Side View – Gas Single Unit

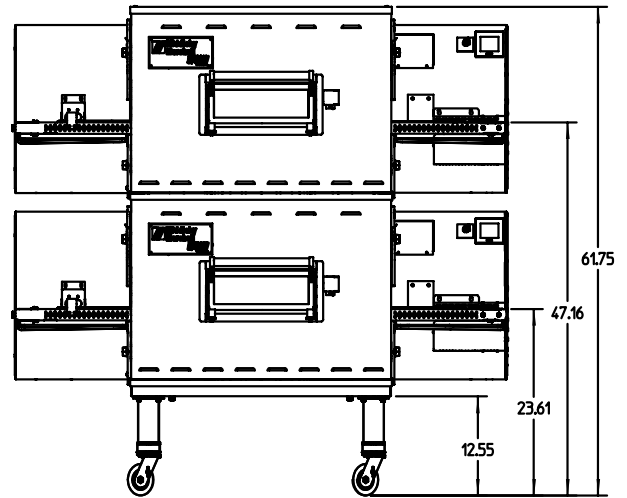

PS3240 Front View – Electric & Gas Double Stacked w/Legs

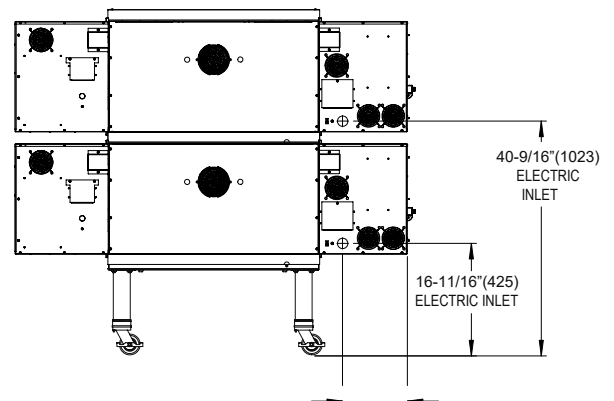

PS3240 Back View – Electric Double Stacked w/Legs

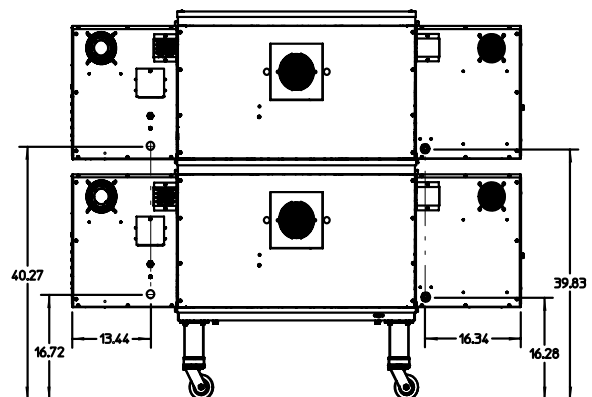

PS3240 Back View – Gas Double Stacked w/Legs

PS3240 Electric or Gas Conveyor Oven

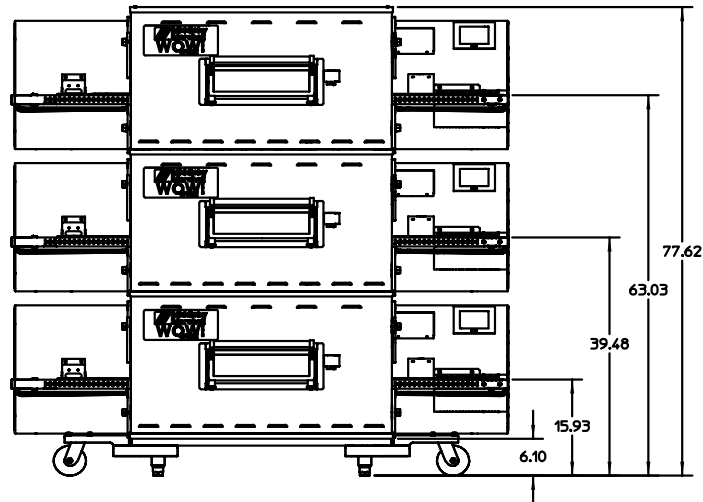

PS3240 Front View – Electric & Gas Triple Stacked w/Outriggers

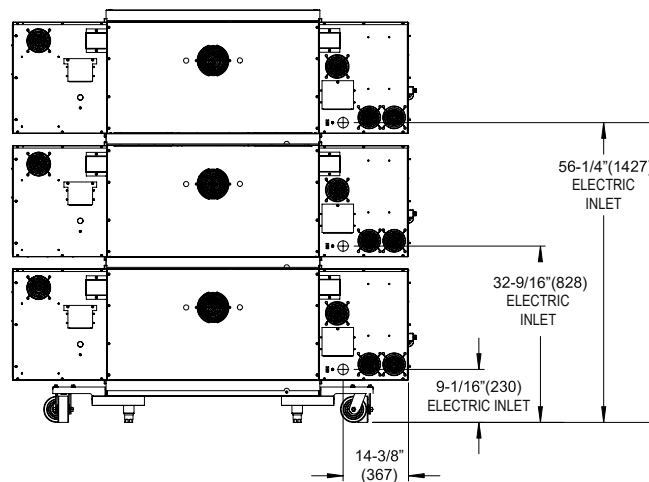

PS3240 Back View – Electric Triple Stacked w/Outriggers

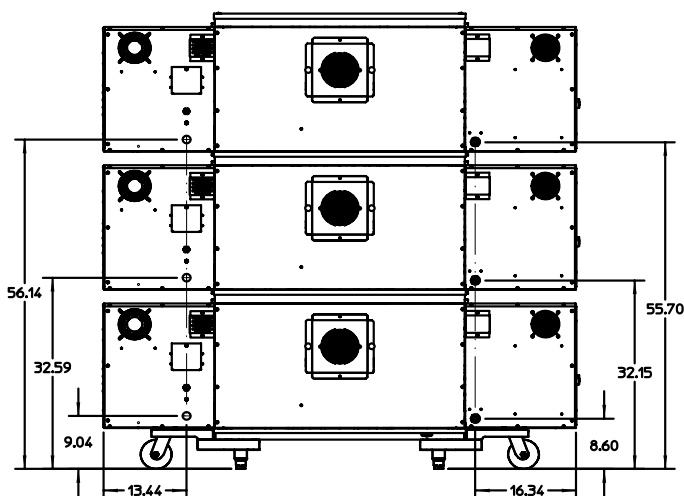

PS3240 Back View – Gas Triple Stacked w/Outriggers

PS3240 Electric or Gas Conveyor Oven

PS3240 Electric Conveyor Oven

VOLTAGE	PHASE	FREQUENCY	RATED HEAT INPUT	AMPERAGE*				SUPPLY	BREAKERS
				L1	L2	L3	N		
208 V	3	50/60 Hz	27.0 kW	85	85	75	-	4-wire (3L + G)	As per local code
240 V	3	50/60 Hz	27.0 kW	75	75	65	-	4-wire (3L + G)	As per local code
380 V	3	50/60 Hz	27.0 kW	51	41	41	10	5-wire (3L + N + G)	As per local code
380 V CE	3	50/60 Hz	27.0 kW	51	41	41	10	5-wire (3L + N + G)	As per local code

*The current draw rating shown above are maximum values for normal operation, amperage draw will be less than the listed value.

PS3240 Gas Conveyor Oven

	ELECTRICAL SPECIFICATIONS	
	USA & STD Export	Europe (CE)
Voltage	208/240 V	220-230 V
Phase	1	1
Frequency	50/60 Hz	50/60 Hz
Current Draw**	4.5 Amp-Run 10Amp-Start	4.5 Amp-Run 10Amp-Start
Supply	3 wire (2 hot, 1 ground)	3 wire (2 hot, 1 ground)
Breakers	As per local code	As per local code
Cord/Plug	Optional 6 ft cord with NEMA# 15-50P plug for 208-240V 3ph ovens.	

NATURAL GAS SPECIFICATIONS	
Supply (Inlet) Pressure	6-8" W.C. (14.9-20.0mbar) *
Regulated Pressure	3.5" W.C.(8.7mbar)
Rated Heat Input	99,000BTU (29.14 kW-hr)

PROPANE GAS SPECIFICATIONS	
Supply (Inlet) Pressure	12-14 "W.C. (29.9-34.9 mbar)*
Regulated Pressure	10" W.C. (24.9 mbar)
Rated Heat Input	99,000BTU (29.14 kW-hr)

The required gas supply pressures of other locations are dependent on the local gas type and on all applicable local codes
Minimum Gas Pipe Sizes:

* Natural Gas - 2" (51 mm) main supply line. One 3/4" (19mm) NPT branch per oven cavity with individual full-flow shutoff valve

* Propane Gas - 1 1/2" (31.8 mm) main supply line. One 3/4" (19mm) NPT branch per oven cavity with individual full-flow shutoff valve

NOTE: Each oven includes (1) 3/4"(19mm)NPT x 48"(1219mm) flexible, vinyl coated gas hose